

Please read this user manual carefully, it contains instructions for the correct assembly.
Please refer to the website www.sabavio.com for updates and other important information. Thank You.

General Specifications

- * Size rretracts: models from 10 to 18 kg .
- * Connection to the legs: 12 mm diameter.
- * 90° Rotation.

- * Voltage from 6 to 8.4 volts.
- * Max Ampere 2.2A.
- * Speed for Open/close: 4.3 seconds.

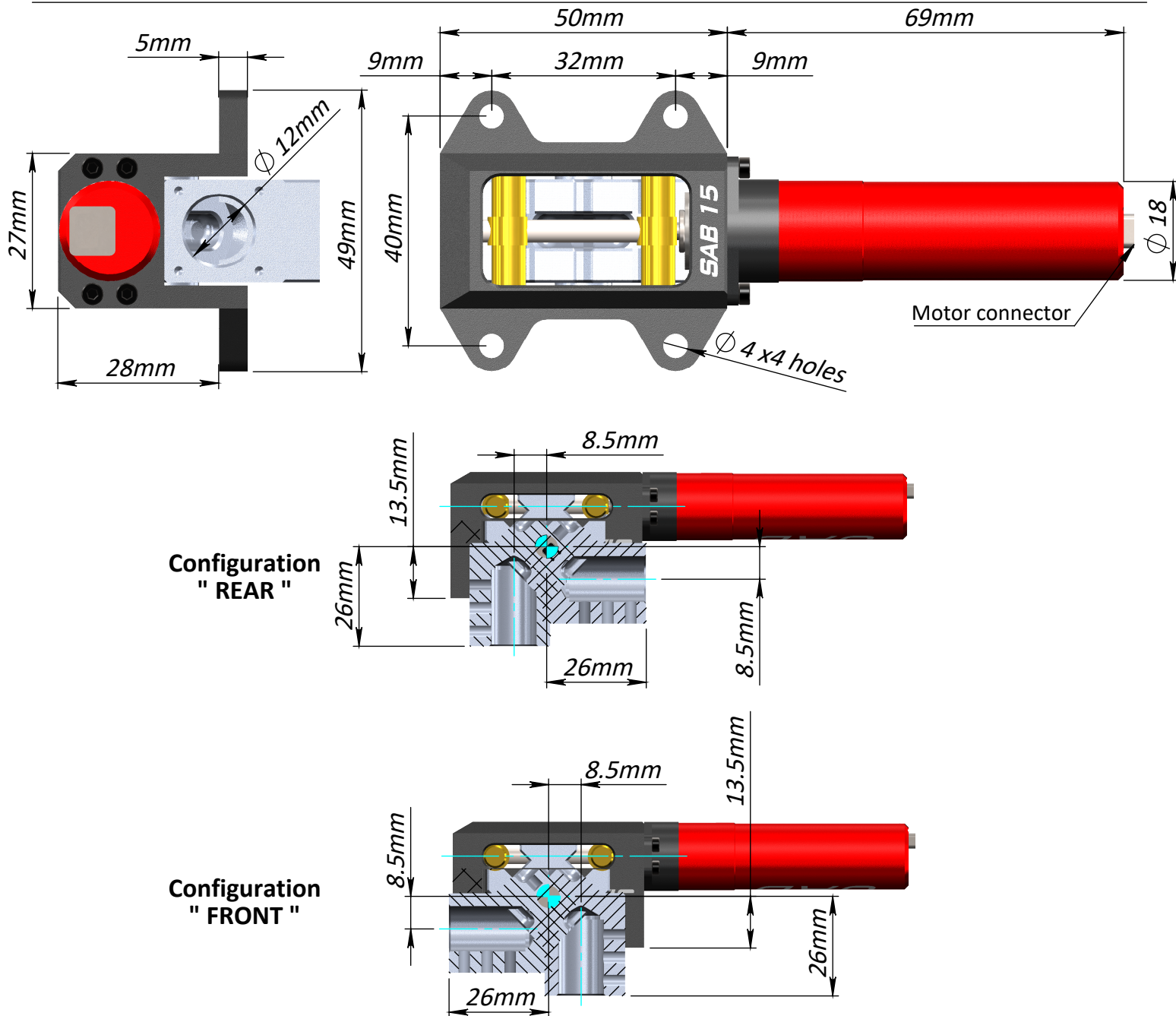

The motor blocked at maximum current may be damaged. Use an appropriate control unit with limitation/stop current.

NOTE:

Use Loctite 242 thread locker in the M3 set screws to connect the legs.

Use a dry oil (WD 40) and keep moving parts lubricated.